

产品尺寸图 (DIMENSION)

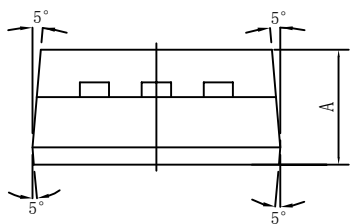
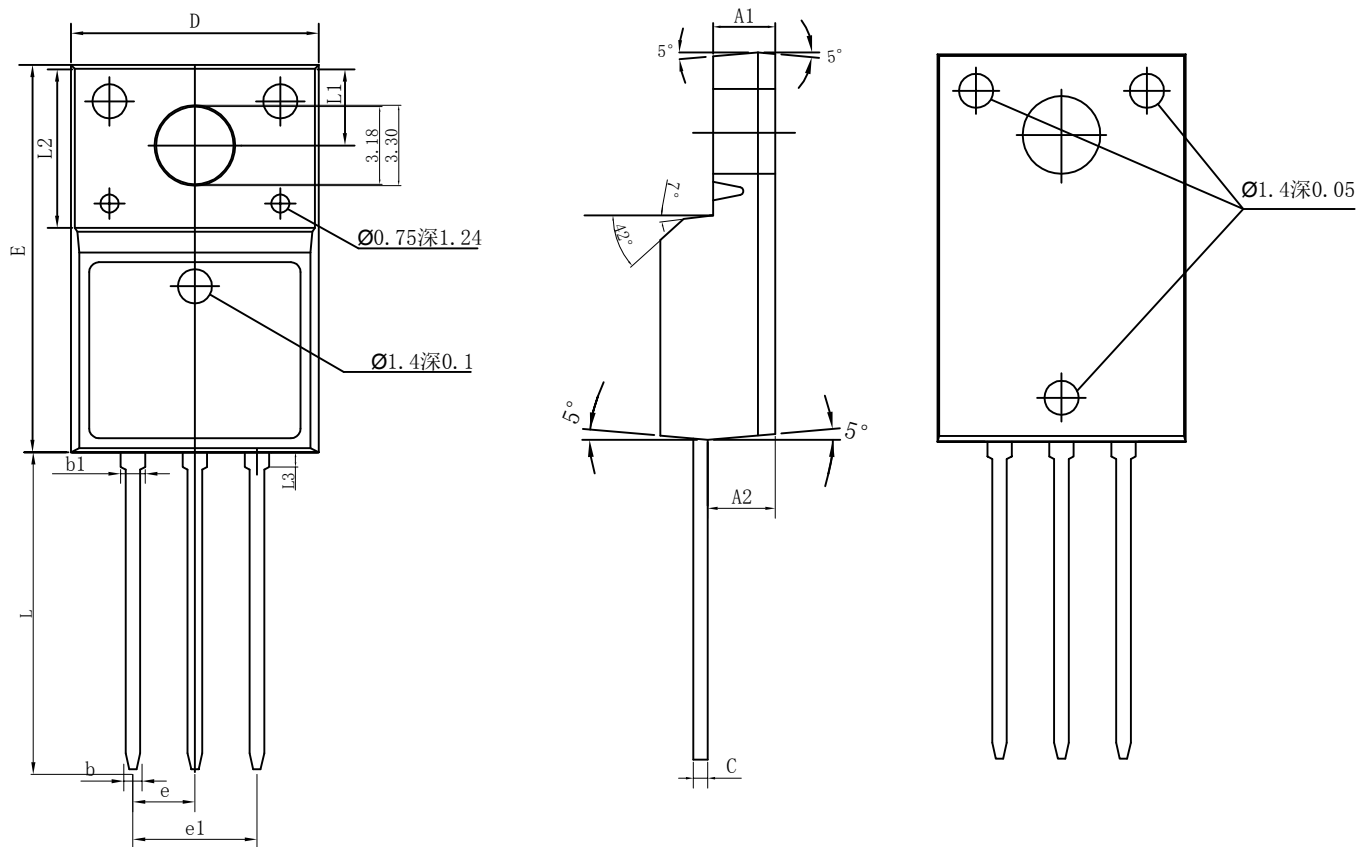

symbol	Dimensions In Millimeters			Dimensions In Inches		
	Min	Nom	Max	Min	Nom	Max
A	4.60	4.70	4.80	0.181	0.185	0.186
A1	2.44	2.54	2.64	0.096	0.100	0.103
A2	2.69	2.76	2.83	0.105	0.108	0.111
b	0.55	0.60	0.65	0.022	0.024	0.026
b1	1.20	1.30	1.40	0.047	0.051	0.055
D	9.96	10.16	10.36	0.392	0.400	0.407
E	15.77	15.87	15.97	0.620	0.624	0.628
L	12.90	13.00	13.05	0.508	0.512	0.514
c	0.45	0.50	0.55	0.018	0.019	0.022
e	—	2.54	—	—	0.100	—
e1	5.00	5.08	5.16	0.197	0.200	0.202
L1	3.20	3.30	3.40	0.125	0.129	0.133
L2	6.58	6.68	6.78	0.259	0.262	0.266
L3	—	—	0.8	—	—	0.315

FSMC

图名 NAME	T0-220FLP		图号 DWG. NO.	DD0105	SH 1 OF 1
材质 MATERIAL	Cu		REV.	A	
单位 UNITS	mm [INCH]	核准 APPROVE	审核 CHECKED	制图 DRAWN	 第三角
日期 DATE	2022.01.27				
比例 SCALE	N. T. S.				